

5800/01 4G GbE Muxponder

A TDM multiplexer for Gigabit Ethernet

Key benefits:

- Plug and play with automatic provisioning, providing easy and fast installation
- Transparent transport of Gigabit Ethernet or Fast Ethernet
- High wavelength utilization via Transmode's Intelligent WDM (iWDMTM) concept using 4Gb/s line rate
- Multi-functional plug-in unit. Same hardware can be used as Muxponder and Regenerator
- Technology agnostic. Pluggable transceivers enable usage in CWDM as well as DWDM networks.
- Dual line ports enabling sub 50ms protection
- Low Power Design ensures low total cost of ownership

The 5800/01 4G Muxponder is a powerful part of Transmode's TS-Series platform enabling cost efficient transport networks based on CWDM and DWDM technology

Optimized for Metro/Access applications

The 5800/01 4G Muxponder is an extremely powerful device for the Metro/access applications where low cost, compact design and low power consumption are crucial components.

Multi functional - Three operating mode

The 5800/01 can be configured into three different modes:

- 4G Muxponder mode
- Double 2.5G Muxponder mode
- 3x Regenerator mode

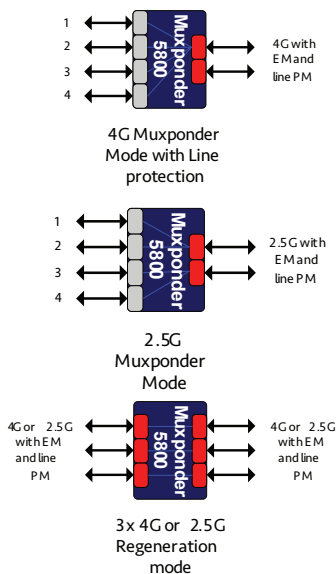

Fig. 1 The three main operating modes of the 5800



In 4G Muxponder mode the 5800/01 electrically multiplexes four GbE or 100Base-T signals onto one 4.25Gb/s wavelength channel. In this mode 4G capable transceivers are used, available in various options supporting links up to 70 km (un-amplified) both for CWDM and DWDM networks. In this mode the 5800/01 also has an in-built Line Protection feature that can be initiated via the management interface.

In Double 2.5G Muxponder mode the 5800/01 electrically multiplexes two GbE or 100Base-T signals onto one 2.5Gb/s wavelength channel. In this mode, the 5800/01 can be seen as two separate Muxponders carrying two GbE or 100Base-T signals each.

The 5800/01 can also be configured into a 3-channel regenerator. The figure below shows an example where 4x GbE channels are carried over a point-to-point network with an intermediate regenerator node. All nodes can be remotely managed via the embedded management channels.

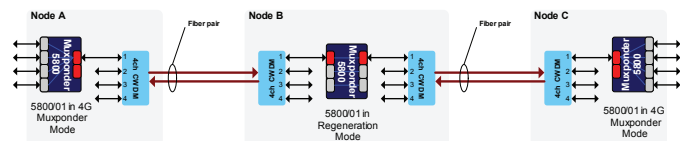

Fig. 2 An example of the 3 channel regenerator mode where 4xGbE channels are carried over a point-to-point network using an intermediate regenerator node

This unparalleled flexibility in hardware reduces the Operational Expenditures (OPEX) as the same plug-in unit can be used to multiplex client signals as well as regenerate the line signal to extend the bridgeable distance.

The regenerator mode can also be used to convert from a CWDM to a DWDM network or to convert from one C/DWDM wavelength to another, by using corresponding transceivers (SFPs) on the appropriate interfaces.

Tailored Network Element options

The 5800/01 MXP can be mounted in any of the TS-Series two chassis options;

- 1U TS-100 chassis
- 6U TS-1100 chassis

This enables a tailored setup depending on current and future capacity needs of the site.

Embedded Management

The embedded management channels enable easy remote management via the line signal. There is therefore no need to provide access to the customer DCN network if the 5800/01 MXP is placed at a customer site

Low Power Design

A fully equipped 5800/01 consumes less than 14W. Low power consumption in combination with a small footprint reduces site costs and enables more capacity to be handled at sites with restrictions on power consumption, cooling and space. As an example, a 5800/01 mounted in a 1U TS-100 chassis will consume less than 24W.



Fig. 3 TS-100 chassis example configuration

Technical specifications:

Supported traffic formats	Gigabit Ethernet Fast Ethernet
Layer-1 performance monitoring	Gigabit Ethernet: Based on CRC and 8B10B coding errors Line signal: Block error based on coding and framing errors
Layer-2 performance monitoring	Channel utilization (%) on GbE clients
Protection	Via two line ports set in 1+1 protection. Non-revertive switching <50ms
Power consumption	Max 14W worst case (with all client ports active and using DWDM SPFs)
Misc line interface features	Embedded management channels on line signals
Operational modes	4G Muxponder mode (4 client ports + 2 line ports for protection) 2.5G Muxponder mode (4 client ports + 2 line ports) 3x Regenerator mode (with embedded management channels on all 6 line ports)
Released traffic combinations	4xGbE with 4G line signal Double 2xGbE with two 2.5G line signals
Interfaces	Client interfaces: SFP MM, SM @ 1310nm/1550nm versions covering ranges from 100m up to 15km. Multi Rate 100Mb/s – 2,125Gb/s. Electrical SFP for Gigabit Ethernet and Fast Ethernet. Line interfaces: SFP 4Gb/s 40km/70km CWDM (up to 16 channels) or 80km DWDM (up to 40 channels), SFP 2.5Gb/s 40km/80km/100km (up to 16 channels) or 80km DWDM (up to 40 channels)

The specifications and information within this document are subject to change without further notice. All statements, information and recommendations are believed to be accurate but are presented without warranty of any kind. Contact Transmode for more details.